

Dimensioning and Tolerancing

Engineering Product Definition and Related Documentation Practices

[This is a preview - click here to buy the full publication](#)

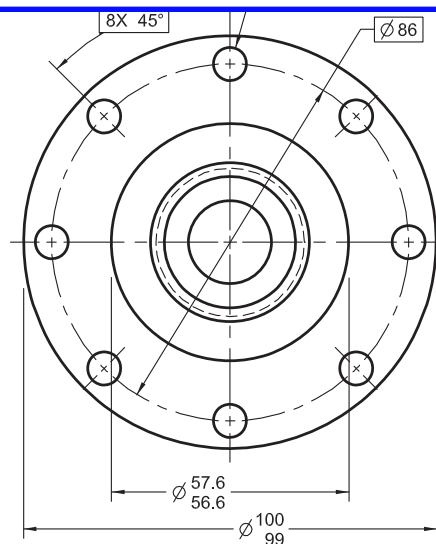

AN INTERNATIONAL STANDARD



**The American Society of
Mechanical Engineers**

ADOPTION NOTICE

ASME Y14.5, Dimensioning and Tolerancing, was adopted on 9 February 2009 for use by the Department of Defense (DoD). Proposed changes by DoD activities must be submitted to the DoD Adopting Activity: Commander, U.S. Army Research, Development and Engineering Center (ARDEC), ATTN: AMSRD-AAR-QES-E, Picatinny Arsenal, NJ 07806-5000. Copies of this document may be purchased from The American Society of Mechanical Engineers (ASME), 150 Clove Road, 6th Floor, Little Falls, NJ 07424-2139; <http://www.asme.org>.

Custodians:

Army — AR
Navy — SA
Air Force — 16

Adopting Activity:

Army — AR
(Project DRPR-2009-003)

Review Activities:

Army — C
Navy — AS, CG, CH, EC, MC, NF, TD
Air Force — 13, 99
DLA — DH
OSD — SE
NSA — NS
Other — CM, MP, DC2

[This is a preview - click here to buy the full publication](#)

NOTE: The activities listed above were interested in this document as of the date of this document. Since organizations and responsibilities can change, you should verify the currency of the information above using the ASSIST Online database at <https://quicksearch.dla.mil>.

ASMC N/A

AREA DRPR

DISTRIBUTION STATEMENT A. Approved for public release, distribution is unlimited.

ASME Y14.5-2018
(Revision of ASME Y14.5-2009)

Dimensioning and Tolerancing

**Engineering Product Definition and
Related Documentation Practices**

[This is a preview - click here to buy the full publication](#)

AN INTERNATIONAL STANDARD



**The American Society of
Mechanical Engineers**

Two Park Avenue • New York, NY • 10016 USA