



Designation: D2290 – 19a

Standard Test Method for Apparent Hoop Tensile Strength of Plastic or Reinforced Plastic Pipe¹

This standard is issued under the fixed designation D2290; the number immediately following the designation indicates the year of original adoption or, in the case of revision, the year of last revision. A number in parentheses indicates the year of last reappraisal. A superscript epsilon (ϵ) indicates an editorial change since the last revision or reappraisal.

This standard has been approved for use by agencies of the U.S. Department of Defense.

1. Scope*

1.1 This test method covers the determination of the comparative apparent tensile strength of most plastic products utilizing a split disk or ring segment test fixture, when tested under defined conditions of pretreatment, temperature, humidity, and test machine speed. This test method is applicable to reinforced-thermosetting resin pipe regardless of fabrication method. This test method also is applicable to extruded and molded thermoplastic pipe.

Procedure A is used for reinforced-thermosetting resin pipe; Procedure B is used for thermoplastic pipe of any size; Procedure C is used for thermoplastic pipe with nominal diameter of 4½ in. (110 mm) and greater. Procedure D is used for polyethylene pipe with a nominal diameter of 14 in. (350 mm) and greater and preferably having wall thickness 1 in. (25 mm) and greater. Procedure E is used for polyvinyl chloride (PVC) pipe with a nominal diameter of 14 in. (350 mm) and greater and having wall thickness 0.5 in. (12.7 mm) and greater.

1.2 The values stated in inch-pound units are to be regarded as standard. The values given in parentheses are mathematical conversions to SI units that are provided for information only and are not considered standard.

1.3 *This standard does not purport to address all of the safety concerns, if any, associated with its use. It is the responsibility of the user of this standard to establish appropriate safety, health, and environmental practices and determine the applicability of regulatory limitations prior to use.*

1.4 *This international standard was developed in accordance with internationally recognized principles on standardization established in the Decision on Principles for the Development of International Standards, Guides and Recommendations issued by the World Trade Organization Technical Barriers to Trade (TBT) Committee.*

¹ This test method is under the jurisdiction of ASTM Committee F17 on Plastic Piping Systems and is the direct responsibility of Subcommittee F17.40 on Test Methods.

Current edition approved Aug. 1, 2019. Published September 2019. Originally approved in 1964. Last previous edition approved in 2019 as D2290 – 19. DOI: 10.1520/D2290-19A

2. Referenced Documents

2.1 *ASTM Standards:*²

- D618 Practice for Conditioning Plastics for Testing
- D1599 Test Method for Resistance to Short-Time Hydraulic Pressure of Plastic Pipe, Tubing, and Fittings
- E4 Practices for Force Verification of Testing Machines

3. Summary of Test Method

3.1 For Procedures A, B, and C, the test specimen is loaded through the suggested self-aligning split disk test fixture (Fig. 1) which applies tensile stress to the test ring. An apparent tensile strength rather than a true tensile strength is obtained in this test because of a bending moment imposed during test at the split between the split disk test fixture. This moment is induced by the change in contour of the ring between the two disk sections as they separate. The test fixture is designed to minimize the effect of this bending moment.

3.2 For Procedure D, ring segment test specimen pairs are loaded into the suggested self-aligning test fixtures (Fig. 2) that are designed to apply direct tensile stress to the reduced areas of the ring segment test specimens (Fig. 3) with minimal bending moment.

3.3 For Procedure E, a single ring segment test specimen is loaded into the suggested self-aligning test fixture (Fig. 4) that is designed to apply direct tensile stress to the reduced areas of the ring segment test specimen (Fig. 5/Fig. 6) with minimal bending moment.

4. Significance and Use

4.1 Split disk and ring segment tensile tests, properly interpreted, provide reasonably accurate information with regard to the apparent tensile strength of plastic pipe when employed under conditions approximating those under which the tests are made.

4.2 Ring tensile tests may provide data for research and development, engineering design, quality control, acceptance

² For referenced ASTM standards, visit the ASTM website, www.astm.org, or contact ASTM Customer Service at service@astm.org. For *Annual Book of ASTM Standards* volume information, refer to the standard's Document Summary page on the ASTM website.

*A Summary of Changes section appears at the end of this standard

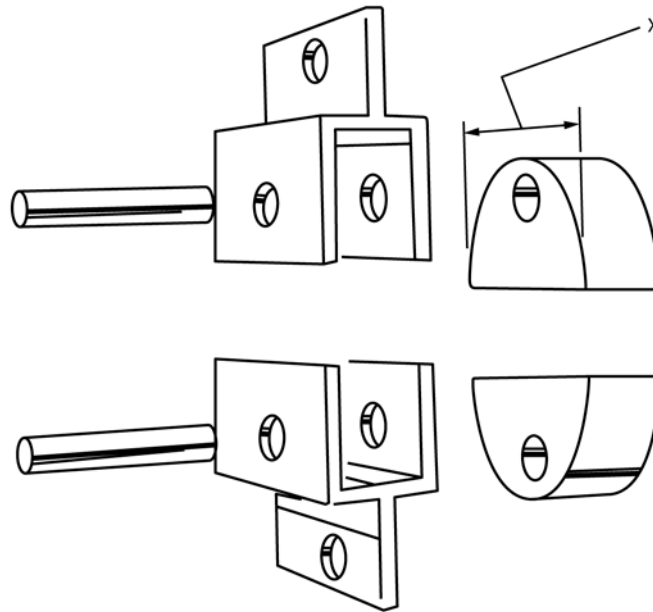

FIG. 1 Test Fixture: Typical

or rejection under specifications, and for special purposes. The test cannot be considered significant for applications differing widely from the load-time scale of the standard test.

NOTE 1—Procedure C has been used on polyethylene and polybutylene pipe to produce results equivalent to Quick Burst results (Test Method D1599) for 4 in. to 8 in. pipes.

5. Apparatus

5.1 *Micrometers*—Suitable ball anvil-type micrometers, reading to at least 0.001 in., for measuring the width and thickness of the test specimens.

5.2 *Testing Machine*—A universal testing machine of the constant-rate-of-cross-head-movement type and comprising essentially the following:

5.2.1 *Drive Mechanism*—A drive mechanism for imparting to the crosshead a uniform controlled velocity with respect to the base, this velocity to be regulated as specified in Section 9.

5.2.2 *Load Indicator*—A load-indicating mechanism capable of showing the total tensile load carried by the test specimen. This mechanism shall be essentially free from inertia lag at the specified rate of testing and shall indicate the load with an accuracy of $\pm 1\%$ of the indicated value. The accuracy of the testing machine shall be verified in accordance with Method E4.

5.3 *Procedure A, B, and C Test Fixture*—The recommended test fixture Procedures A, B, and C is shown in Fig. 1. The width of the split disk for Procedure A and Procedure B shall be at least 0.1 in. greater than the width of the specimen. The width of the split disk for Procedure C shall be 2.0 in. \pm 0.1 in. The supports for holding the tension test fixture shall be self-aligning, that is, they shall be attached to the fixed and movable member of the test machine, respectively, in such a manner that they move freely into alignment as soon as any load is applied, so that the direction of the applied pull is directly perpendicular to the split axis of the test fixture.

5.4 *Procedure D Test Fixture*—A tension test fixture for Procedure D is illustrated in Fig. 2. The supports for holding the tension test fixture shall be self-aligning, that is, they shall be attached to the fixed and movable member of the test machine, respectively, in such a manner that they move freely into alignment as soon as any load is applied, so that the direction of the applied pull is directly perpendicular to the split axis of the test fixture.

NOTE 2—In Fig. 2, the 2.00-in (50.8 mm) wide by 5.00-in (127 mm) long openings are suitable for ring segment specimens that are 1.6 to 1.8 in (40.6 to 45.7 mm) wide and from 1.0 to 4.5 in (25.4 to 114.3 mm) wall thickness. For ring segment specimen wall thickness greater than 4.5 in (114.3 mm), opening size may be adjusted appropriately. Opening size should allow 0.10 in (2.5 mm) minimum width clearance on each side, and at least 0.50 in (12.7 mm) wall thickness clearance. Ring segment test specimen securing pins 0.50-in (12.7 mm) diameter have been found suitable. Tapering or rounding the ends of the securing cross pins facilitates installation into the ring segments specimens. See Fig. 2 and Fig. 3.

5.5 *Procedure E Test Fixture*—A test fixture for Procedure E is illustrated in Fig. 4. The Test fixture shall be self-aligning, that is, it shall be attached to the fixed and movable member of the test machine, respectively, in such a manner that it moves freely into alignment as soon as any load is applied, so that the direction of the applied pull is directly perpendicular to the split axis of the test fixture.

5.6 *Conditioning Apparatus*—Apparatus for maintaining temperature and relative humidity for conditioning prior to test, in accordance with Section 7.

6. Test Specimen

6.1 Test specimen for Procedure A shall be full-diameter, full-wall thickness rings cut from reinforced thermosetting resin pipe by any suitable means. Specimens shall conform to Fig. 7. Specimens shall have a minimum overall width of 0.90 in., and a minimum width in the reduced section(s) of 0.55 in.

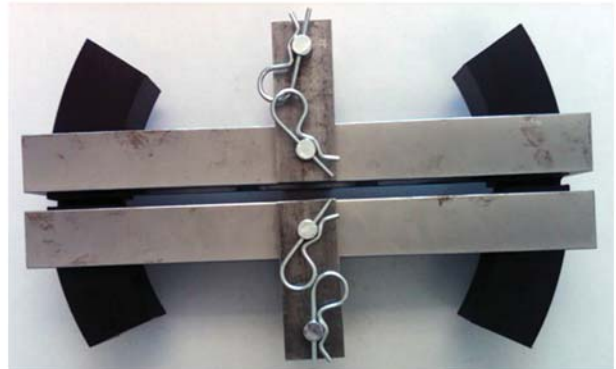
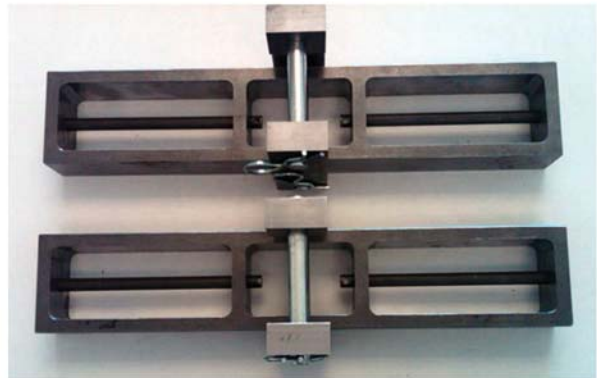
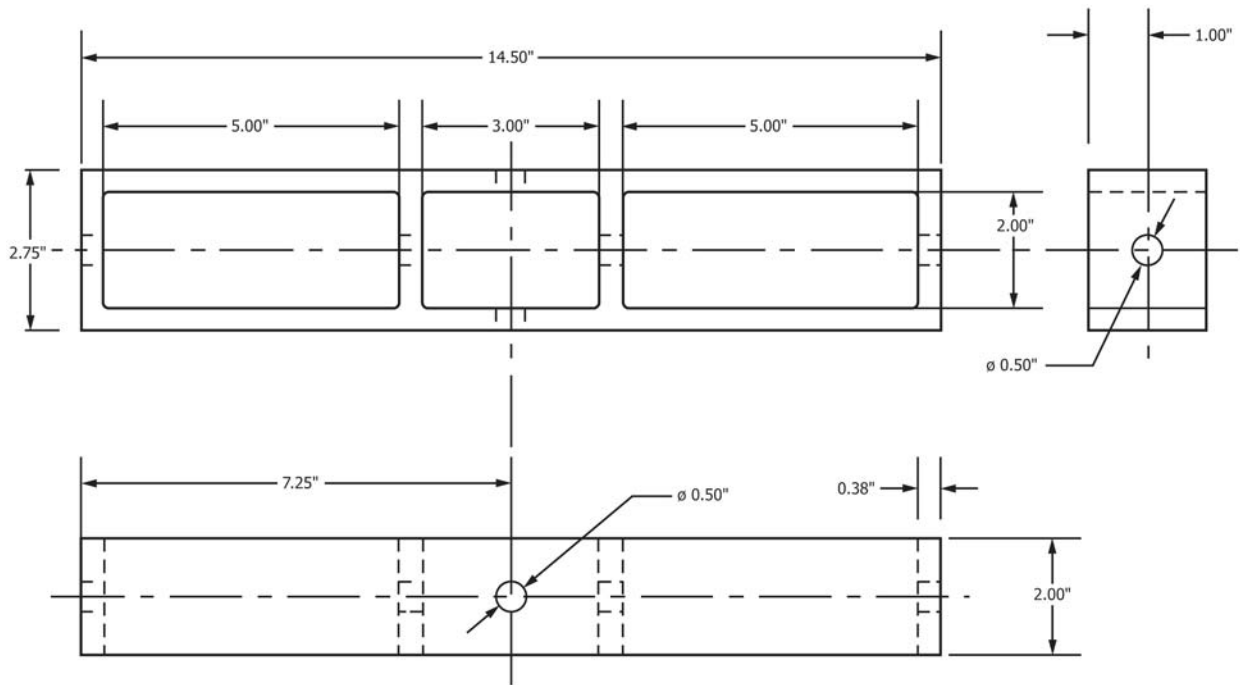

Fixture dimensions are for illustration only. See Note 2.

FIG. 2 Procedure D Test Fixture

The number of reduced areas shall be one or two. If two, they must be located 180° apart. Reduced areas must be centered relative to the specimen width to within 0.05 in.

6.2 Test specimens for Procedure B shall be full-diameter, full-thickness rings cut from thermoplastic pipe, by any suitable means, as shown in Fig. 8. The minimum width of the

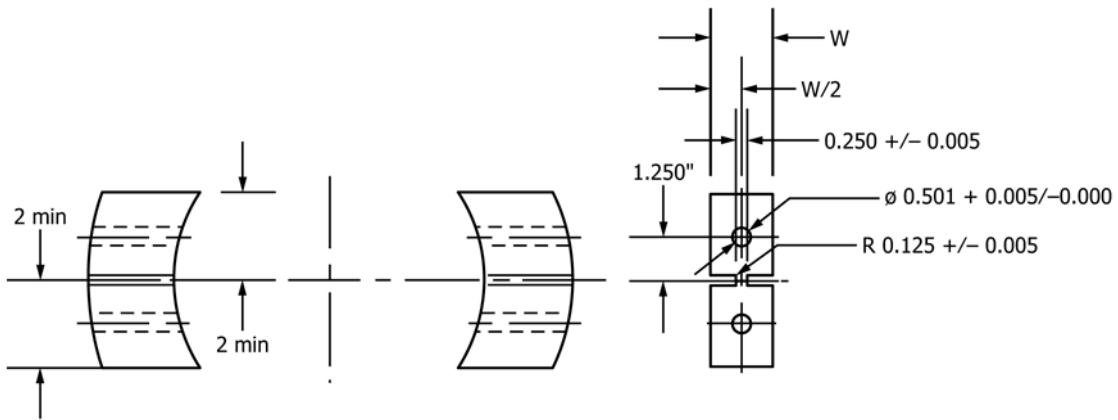

FIG. 3 Ring Segment Specimens 1 and 2 for procedure D (See 6.4.2 and 6.4.3.)

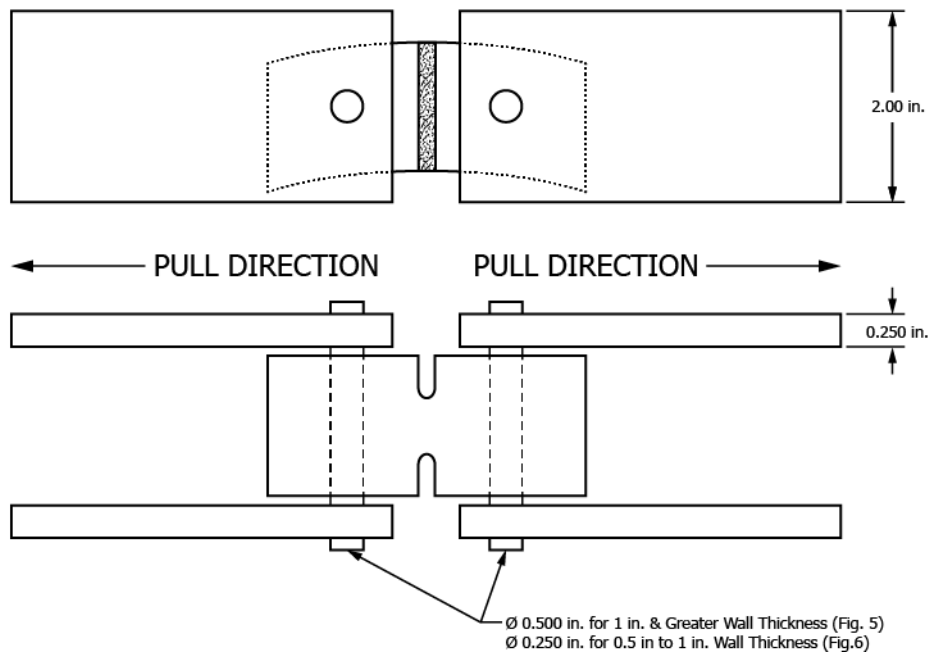

FIG. 4 Self Aligning Test Fixture for Procedure E

ring, W , per Fig. 8 shall be 0.50-in. The maximum width of the ring shall be 2.00-in. Reduced areas shall be machined as shown in Fig. 8 and shall be located at the point of minimum wall thickness and at 180° thereto except when the test is used for specialized purposes (see Note 3). The reduced area, W_r , per Fig. 8, shall be at least 0.25-in smaller than W . The ratio of the width of the ring, W , to the reduced area, W_r , shall be at least 2.0. The width range of the reduced area, W_r , shall be 0.250-in. minimum to 0.750-in. maximum. Within the 0.250 to 0.750- in. allowable range for W_r , the maximum difference between W_r at the point of minimum wall thickness and W_r at 180° opposite shall be 0.020-in. The maximum variation in W_r from the outside diameter to the inside diameter of the test specimen shall be 0.010-in. The reduced areas of the specimen must be free of machining marks and uniform in cross section.

NOTE 3—The reduced sections for the extruded or molded specimens can be located at any points on the periphery of the specimen provided they are 180° apart, that is, even at the weld or “knit” line of the specimen if the strength of these areas is being investigated.

NOTE 4—Specimen ring width, W , per Fig. 8 may be varied between 0.50 in. and 2.00 in. For larger diameter pipes with greater wall thickness, specimen stability during testing is improved when ring width is greater.

6.3 Test specimens for Procedure C shall be cut normal to the pipe axis with parallel sides. The width of the specimen shall be nominally 1.75 in. to 2.00 in. Two areas, one of which includes the minimum pipe wall thickness and the other 180 deg opposite, shall be wet sanded to remove cutting marks; care must be exercised to retain the rectangular cross-section of the prepared areas.

6.4 Test samples for Procedure D shall be full rings cut normal to the pipe axis with parallel sides. The width of ring samples shall be nominally 2.00 ± 0.2 in. (50.8 ± 5.1 mm). One ring sample is used to produce ring segment Specimens 1 and 2.

6.4.1 Ring sample wall thickness shall be measured, and the minimum wall thickness and the point 180 degrees opposite shall be located and marked.