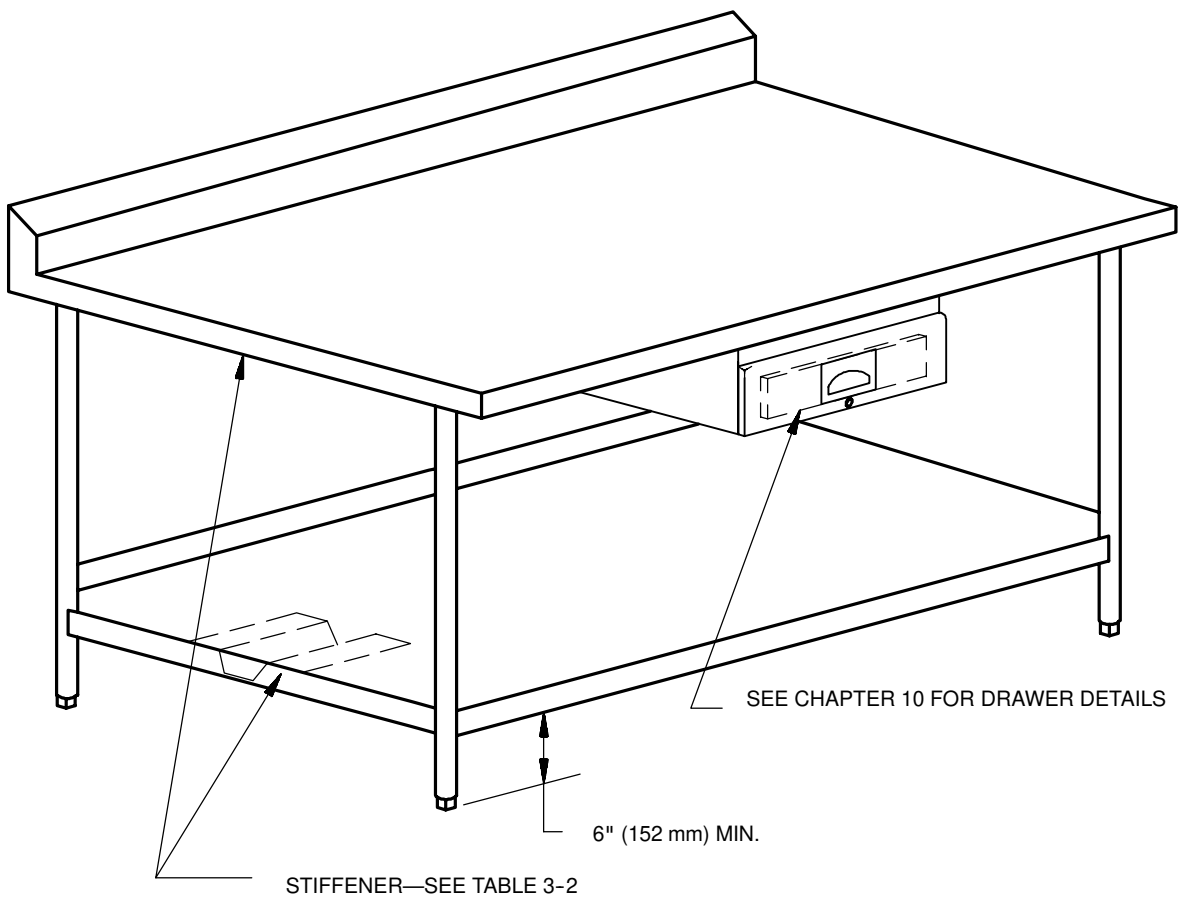

**FIGURE 3-1 WORK TABLE**

SEE FIGURES 2-3 AND 2-4 FOR EDGE AND BACKSPLASH DETAILS.  
SEE TABLES 3-1 AND 3-2 FOR TOP AND SHELF UNDERBRACING SPECIFICATIONS.



**FIGURE 3-2 WORK TABLE**

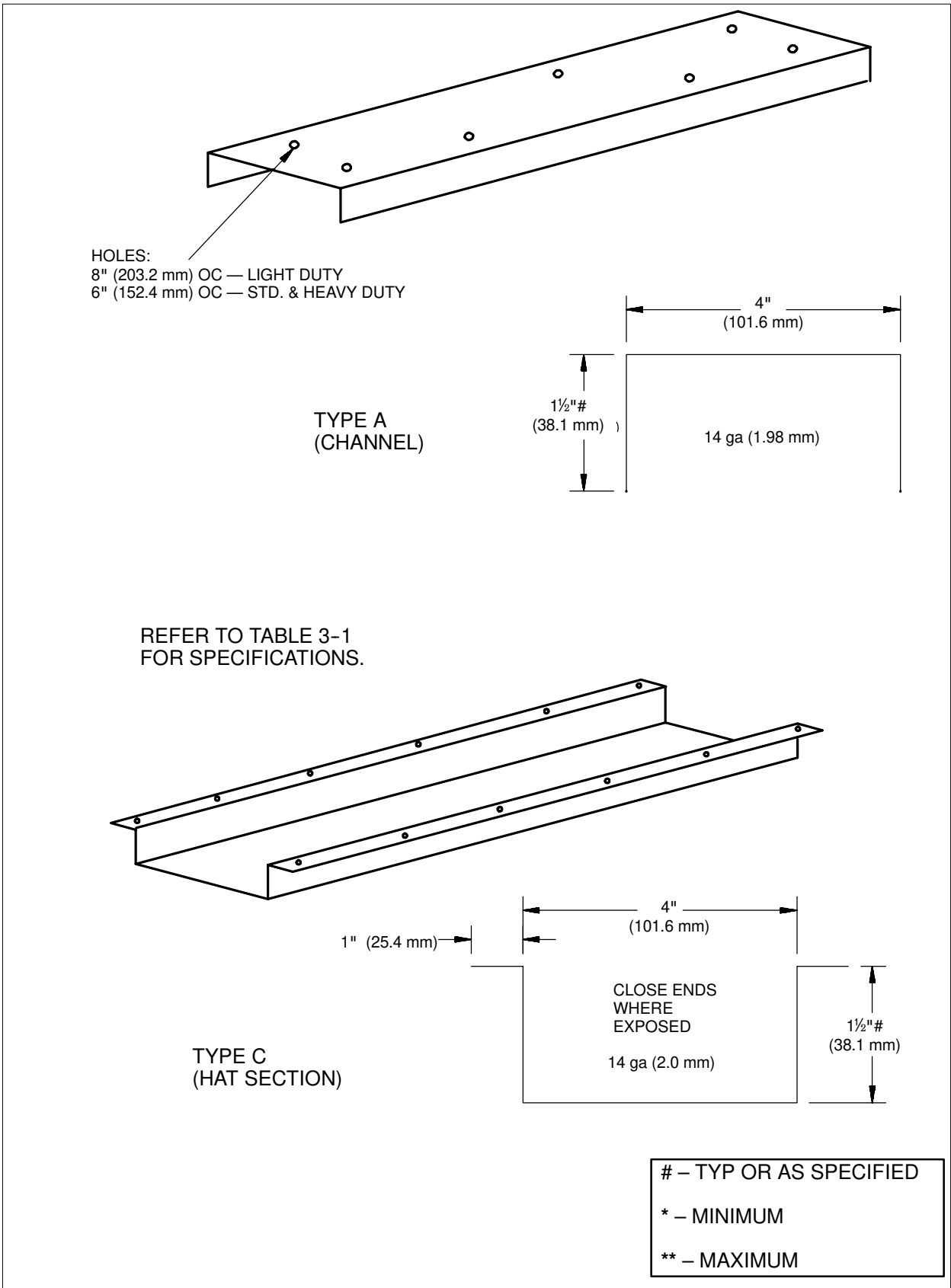



**FIGURE 3-3 WORK TABLE UNDERBRACING**



This is a preview. [Click here to purchase the full publication.](#)



**FIGURE 3-4 UNDERBRACING DETAILS**

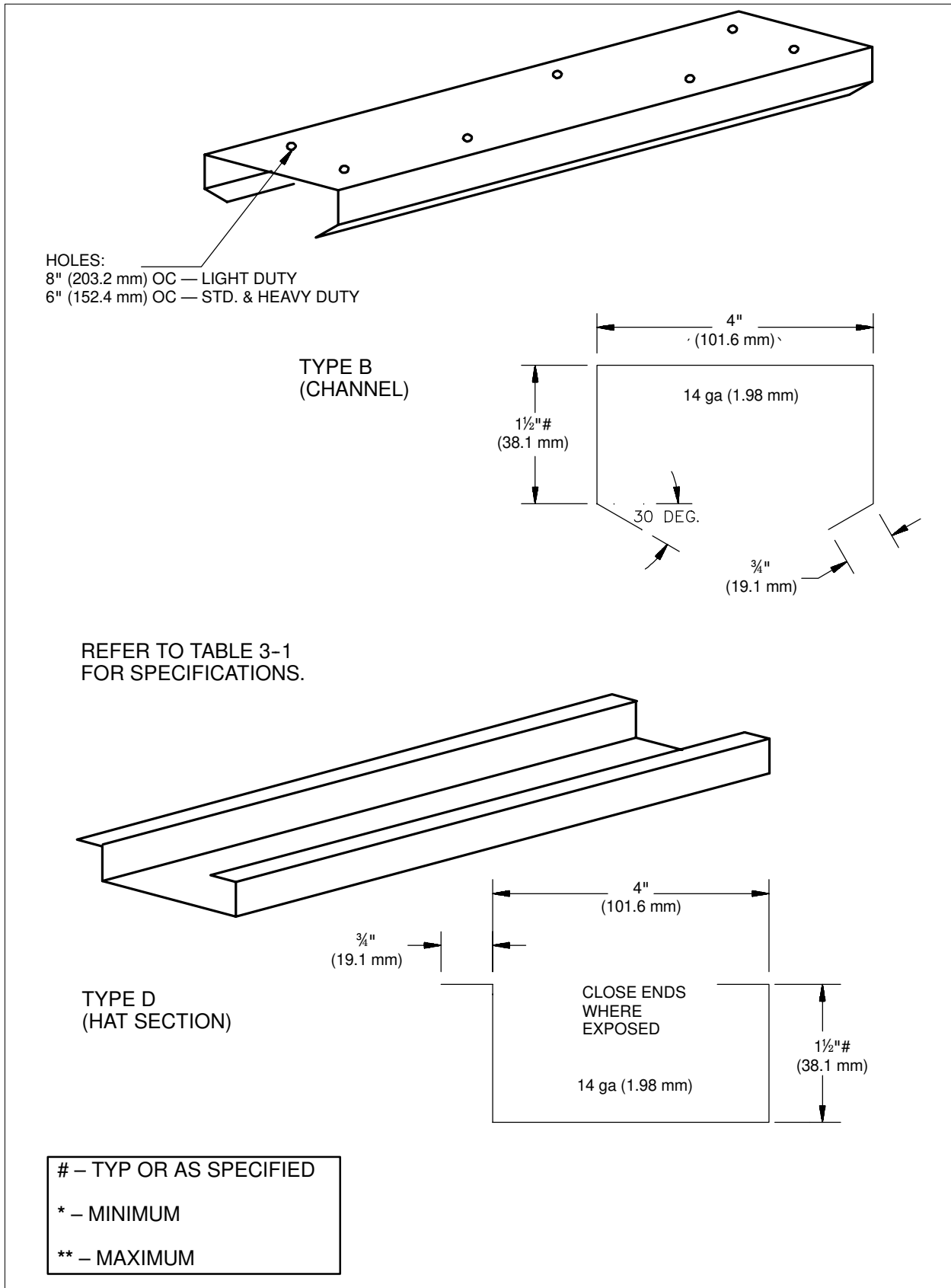

**FIGURE 3-5 UNDERBRACING DETAILS**



	WIDTH	LENGTH	GAUGE TOP	LEG QTY.	TOP UNDERBRACING			EDGE UNDERBRACING		
					A 14 GA. 4" X 1-1/2"	B 14 GA. 4" X 1-1/2" 3/4"	C 12 GA. 4" X 1-1/2" 3/4"	D 12 GA. 4" X 1-1/2" 3/4"		
LITE	24" TO 30"	24" TO 60"	16	4	1					
STD.	24" TO 36"	24" TO 60"	16	4		1				
		61" TO 72"	16	4		2				
		73" TO 96"	16	6		1				
HEAVY		97" TO 120"	16	6		2				
	37" TO 54"	42" TO 72"	16	4		2				
		73" TO 84"	16	6		2				
		85" TO 120"	16	6				2		
	30" TO 54"	36" TO 72"	16	4					1	YES
		73" TO 84"	16	6					1	YES
	85" TO 108"		14	6				2		YES
DUTY DESCRIPTION										
NOTES										
LIGHT DUTY – E.G. PORTABLE, WRAPPING SPACER TABLE.					SEE GENERAL SPEC.					
STANDARD – E.G. PORTABLE PREP. TABLE, BAKERS TABLE, NON-COMMERCIAL DISH-WASHING TABLES.					SEE EDGE SPEC.					
HEAVY DUTY – E.G. BUTCHER, WORK TABLE, COMMERCIAL DISHWASHING TABLES					SEE LEG AND UNDERBRACING SPEC.					

**Table 3-1 Top Reinforcement Specifications**



	WIDTH (mm)	LENGTH (mm)	GAUGE TOP	LEG QTY.	TOP UNDERBRACING			EDGE UNDERBRACING	
					A 1.98 mm 100 x 38.1 mm	B 1.98 mm 100 x 38.1 mm 3/4"	C 2.78 mm 100 x 38.1 mm 3/4"	D 2.78 mm 100 x 38.1 mm 3/4"	
LITE	610 TO 760	610 TO 1525	1.27 mm	4	1				
STD.	610 TO 915	610 TO 1525	1.59 mm	4		1			
		1550 TO 1830	1.59 mm	4		2			
		1855 TO 2440	1.59 mm	6		1			
HEAVY		2465 TO 3050	1.59 mm	6		2			
	940 TO 1370	1065 TO 1830	1.59 mm	4		2			
		1855 TO 2135	1.59 mm	6		2			
		2160 TO 3050	1.59 mm	6			2		
	760 TO 1370	915 TO 1830	1.59 mm	4				1	YES
	1855 TO 2135	1.59 mm	6				1	YES	
	2160 TO 2745	1.98 mm	6				2	YES	
DUTY DESCRIPTION									
LIGHT DUTY – E.G. PORTABLE, WRAPPING SPACER TABLE.					NOTES				
STANDARD – E.G. PORTABLE PREP. TABLE, BAKERS TABLE, NON-COMMERCIAL DISH-WASHING TABLES.					SEE GENERAL SPEC.				
HEAVY DUTY – E.G. BUTCHER, WORK TABLE, COMMERCIAL DISHWASHING TABLES					SEE EDGE SPEC.				
					SEE LEG AND UNDERBRACING SPEC.				

**Table 3-1M Top Reinforcement Specifications**



This is a preview. Click here to purchase the full publication.

	WIDTH	LENGTH	GAUGE SHELF	SHELF UNDERBRACING			EDGE UNDERBRACING		
				A 14 GA. 4" X 1-1/2"	B 14 GA. 4" X 1-1/2" 3/4"	C 12 GA. 4" X 1-1/2" 3/4"	D 12 GA. 4" X 1-1/2" 3/4"	E 14 GA. 4" X 1-1/2" 3/4"	
LITE	24" TO 30"	24" TO 60"	18	1					
STD.	24" TO 36"	24" TO 60"	18	1					
		61" TO 120"	18	2					
	37" TO 54"	36" TO 84"	18	2					
HEAVY		85" TO 120"	18			2			
	30" TO 54"	36" TO 84"	16			1	1	1	1
		85" TO 120"	16			1	2	1	1
DUTY DESCRIPTION				NOTES					
LIGHT DUTY – E.G. PORTABLE, WRAPPING SPACER TABLE.				SEE GENERAL SPEC.					
STANDARD – E.G. PORTABLE PREP. TABLE, BAKERS TABLE, NON-COMMERCIAL DISH-WASHING TABLES.				SEE EDGE SPEC.					
HEAVY DUTY – E.G. BUTCHER, WORK TABLE, COMMERCIAL DISHWASHING TABLES				SEE LEG AND UNDERBRACING SPEC.					

**Table 3-2 Shelf Reinforcement Specifications**





	WIDTH (mm)	LENGTH (mm)	GAUGE SHELF	SHELF UNDERBRACING			EDGE UNDERBRACING		
				A 1.98 mm 100 x 38.1 mm 3/4"	B 1.98 mm 100 x 38.1 mm 3/4"	C 12 GA. 100 x 38.1 mm 3/4"	D 12 GA. 100 x 38.1 mm 3/4"	E 1.98 mm 100 x 38.1 mm 3/4"	
LITE	610 TO 760	610 TO 1525	1.27 mm	1					
STD.	610 TO 915	610 TO 1525	1.27 mm	1					
		1550 TO 3050	1.27 mm	2					
	940 TO 1370	915 TO 2135	1.27 mm	2					
HEAVY		2160 TO 3050	1.27 mm			2			
	760 TO 1370	915 TO 2135	1.59 mm			1		1	
		2160 TO 3050	1.59 mm			1		2	1
				DUTY DESCRIPTION			NOTES		
LIGHT DUTY – E.G. PORTABLE, WRAPPING SPACER TABLE.				SEE GENERAL SPEC.					
STANDARD – E.G. PORTABLE PREP. TABLE, BAKERS TABLE, NON-COMMERCIAL DISH-WASHING TABLES.				SEE EDGE SPEC.					
HEAVY DUTY – E.G. BUTCHER, WORK TABLE, COMMERCIAL DISHWASHING TABLES				SEE LEG AND UNDERBRACING SPEC.					

**Table 3-2M Shelf Reinforcement Specifications**



This is a preview. Click here to purchase the full publication.

## CHAPTER 4

# SHELVES

This is a preview. [Click here to purchase the full publication.](#)